

**Phillips Oval Head SEMS w/
Finishing Washer, Spaced Thread** **SELF-DRILLING**

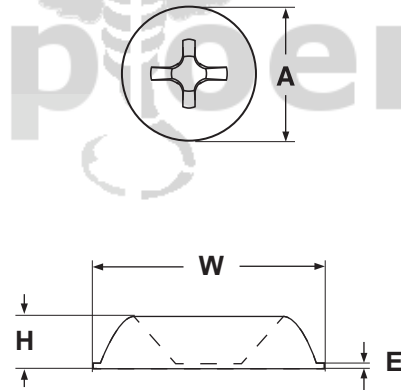
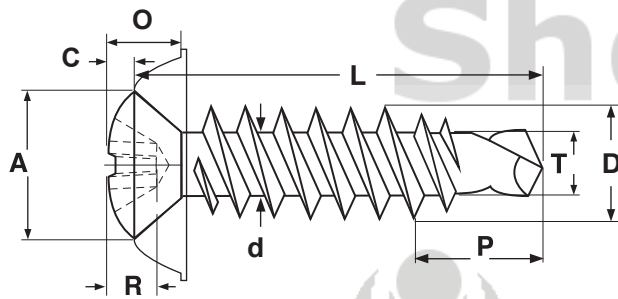

#6 OVAL PHILLIPS Hd / #8 SELF-DRILL SCREW SEMS w/FINISHING WASHER, SPACED THRD																			
Nom. Diam & Threads per Inch	A		O	R		C	D		d		P	T		H		W		E	
	Head Diameter		Total Head Hght	Recess Depth		Head Crown Hght	Major Diameter		Minor Diameter		Point Length	Point Diameter		Washer Height		Washer Outside Diameter		Washer Lip Thickness	
	Max	Min	Ref	Max	Min	Ref	Max	Min	Max	Min	Ref	Max	Min	Max	Min	Max	Min	Max	Min
8 - 18	.262	.238	.117	.094	.069	.045	.166	.161	.122	.116	.211	.130	.128	.118	.102	.508	.496	.020	.016
Tolerance on Length				Up to 1", incl.: ± 0.030								Over 1": ± 0.050							

Description	A screw with a countersunk head, rounded top that protrudes above the surface when set, spaced thread and a self-drilling point with a pre-assembled, free-spinning countersunk finishing washer.
Applications/ Advantages	Popular for use in HVAC applications and certain gutter installations. The captive finishing washer saves time during installation process.
Material	Screw: AISI 1022 or equivalent steel; Finishing Washer: Can be punched from hot-rolled, hot-rolled and pickled, or cold-rolled steel; or shall be machined from bar stock or tubing; or may be forged at the manufacturer's option.
Heat Treatment	Screws shall be quenched in liquid and then tempered by reheating to 625°F minimum.
Case Hardness	Screw: Rockwell C52 -58
Case Depth of Screw	No. 8 diameter: .004 - .009
Core Hardness of Screw	Rockwell C32 - 40 (after tempering)
Plating	See Appendix-A for plating information.